

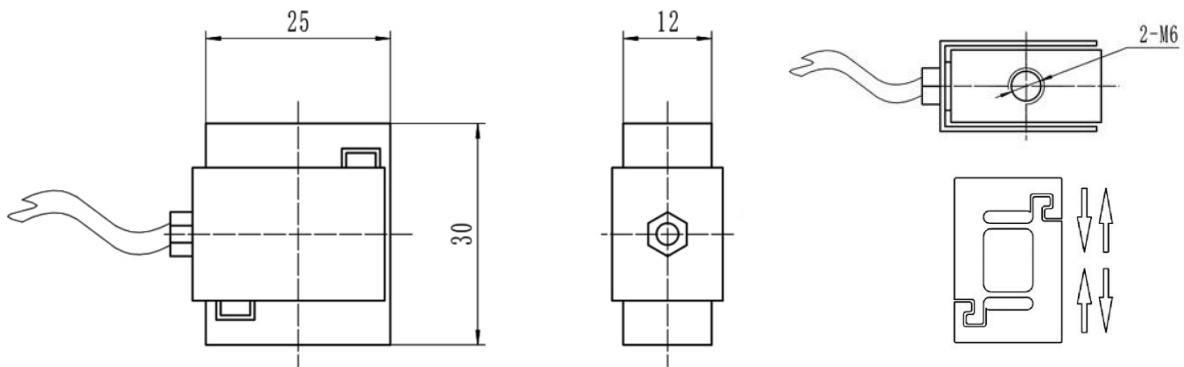

**Features:**

- ◆Capacity : 1-100kg
- ◆Material: stainless steel
- ◆Type: S type
- ◆Defend grade: IP67.
- ◆Application: electronic crane scale, hopper scale, mechanical conversion scale and other electronic weighing devices.

Electrical connection and Dimensions:(dimension unit: mm)



Specifications:		
capacity	kg	1,2,3,5,10,15,20,30,50,100
safe overload	%FS	150
ultimate overload	%FS	200
rated output	mV/V	1.5±0.5
excitation voltage	Vdc	5~ 15
combined error	%FS	± 0.05
zero balance	%FS	± 1.00
non-linearity	%FS	± 0.05
hysteresis	%FS	± 0.05
repeatability	%FS	± 0.05
creep	%FS/30min	± 0.05
input resistance	Ω	385± 35Ω
output resistance	Ω	350± 3Ω
insulation resistance	M Ω	≥ 5000 @ 100 Vdc
operating temperature range	°C	-20 ~ +55
compensated temperature range	°C	-10 ~ +40
temperature coefficient of SPAN	%FS/10°C	± 0.10
temperature coefficient of ZERO	%FS/10°C	± 0.10
Electrical connection	cable	4 core shielded PVC cable, 2m excitation(+):Red excitation(-):Black signal(+):Green signal(-):White

※Ordering code: model-capacity- rated output-accuracy-defend grade- the length of cable